



BEMBRIDGE SAILING CLUB (BSC)
SAILING INSTRUCTIONS (SIs) - 2024

1 RULES

- 1.1 All events to which these sailing instructions apply are governed by the rules as defined in *The Racing Rules of Sailing*.

2 CHANGES TO SAILING INSTRUCTIONS

- 2.1 These SIs may be changed as follows:

(a) By posting the change on the official notice board at least 3 hours before the starting time of the first race to which the change will apply, except that any change that will bring forward the starting time of a race will be posted by no later than 18:00 on the day before it takes place (and any change that will call off or significantly put back the starting time of any race should be posted by the same time);

(b) By displaying the change on a board on the Committee Boat (so as to be readable by competitors in the vicinity of the Committee Boat) and displaying flag L with one sound;

(c) By displaying flag L with one sound on the Committee Boat or Club Finishing Line flagstaff and communicating the change verbally to each and every boat in the relevant class(es), either by hail or over VHF radio (see SI 3.3).

3 COMMUNICATIONS WITH COMPETITORS

- 3.1 Notices to competitors will be posted on the official notice board located at Bembridge Sailing Club and at www.bembridgesailingclub.org

- 3.2 On the water, the race committee intends to monitor and communicate with competitors on VHF radio channel 77.

- 3.3 The following communications may be made by the race committee on VHF channel 77.

- Change of course
- Race Management information
- Safety Information

Should VHF channel 77 be unusable an alternative ship-to-ship channel shall be displayed on the stern of the committee boat.

- 3.4 A boat shall not make radio transmissions while racing, other than on safety matters or on race management matters to the race committee, nor shall she solicit radio communications or use a mobile telephone to gain information that would constitute outside help under **RRS 41**.

4 CODE OF CONDUCT

- 4.1 Competitors and support persons shall comply with reasonable requests from race officials.

5 SIGNALS MADE ASHORE

- 5.1 Signals made ashore will be displayed on the Club Finishing Line flagstaff.

- 5.2 When flag AP is displayed ashore, '1 minute' is replaced with 'not less than 60 minutes' in Race Signals AP.









- 5.3 Flag D with one sound means 'Boats shall not leave the harbour until this signal is made. The

warning signal will not be made before the scheduled time or less than 30 minutes after flag D is displayed.'

6 SCHEDULE OF RACES

6.1 The schedule of races is as given in the NoR (Please refer to the club programme).

7 CLASS FLAGS

Flag	Class	Flag	Class
 Flag R	Redwing Class	 Flag 4	Dinghy Handicap (PY 1250 and over)
 NN8	Bembridge One Design	 Flag 8	ILCA 4 (4.7)
 Flag O	International Optimist & RS Tera	 Flag F	RS Feva
 Flag 7	Solent Scow	 Flag 3	Dinghy Handicap (under PY 1250)

8 RACING AREA

8.1 The general racing area is shown in Appendix 3.

9 COURSES

9.1 The course to be sailed will be displayed using letters, numbers, or symbols (see Appendix 2) on the Committee Boat.

9.2 Please see Appendix 1 for diagrams of the set courses that may be used for club racing. If a set course is to be used the committee vessel will display black board with a white number to indicate which course is to be sailed. (E.g. 1 = Special Course 1).

9.3 An **ORANGE** background to a letter, number or symbol indicates that the mark must be rounded to **PORT**. A **GREEN** background to the letter, number or symbol indicates the mark must be rounded to **STARBOARD**. The £ board (white £ on black background) indicates that competitors must pass through the line at the end of each round.

9.4 A white diamond on a black background will indicate the number of required beats. See Appendix 2

9.5 When a **BLACK & ORANGE** chequered board is displayed, the mark(s) preceding it shall be rounded once before continuing on to the marks displayed after it for the number of beats indicated.

9.6 If Code Flag 3rd Substitute  is displayed from the Committee Boat at the start, the race will finish at the club Finish Line.

10 MARKS

10.1 Mark(s) that are used for club racing are set out in Appendix 2 and can also be viewed on the racing buoy chart in Appendix 3.

11 THE START

11.1 Races will be started using **RRS 26** with the warning signal made 5 minutes before the starting signal.

- 11.3 The starting line is between a staff displaying an orange flag on the starting vessel at the starboard end and the course side of the port-end starting mark.
- 11.4 Boats whose warning signal has not been made shall avoid the starting area during the starting sequence for other races.
- 11.5 If any part of a boat's hull is on the course side of the starting line during the two minutes before her starting signal and she is identified, the race committee will attempt to broadcast her sail number on VHF channel 77. Failure to make a broadcast or to time it accurately will not be grounds for a request for redress. **This changes RRS 62.1(a).**
- 11.6 If any part of a boat's hull is on the course side of the starting line at her starting signal and she is identified, the race committee will attempt to hail her sail number. Failure to hail her number, failure of her to hear such a hail, or the order in which boats are hailed will not be grounds for a redress for request. **This changes RRS 62.1(a).**
- 11.7 A boat that does not start within 5 minutes after her starting signal will be scored Did Not Start without a hearing. This changes **RRS A5.1** and **A5.2**.

12 CHANGE OF THE NEXT LEG OF THE COURSE

- 12.1 In addition to the options for signalling a change of course set out in RRS 33(a) and (b), the Race Committee may signal a change of course by displaying flag C together with a revised list of marks to be passed or rounded after that mark (as per SI 9) with repetitive sound signals. This changes RRS 33.
- 12.2 In the event that the Race Committee is unable to make a course change signal visually, a course change may also be announced over VHF radio (see SI 3.3). This changes RRS 33.**13 THE**

FINISH

- 13.1 Committee Boat: The finishing line is between a staff displaying a blue flag on the finishing vessel at the starboard end and the course side of the port end finishing mark.
- 13.2 Club Finish Line: The Club Finishing line is between the eastern end of the groyne projecting from St Helen's shore at the harbour entrance and the black and white flagstaff in front of the Club. (Also See **SI 9.5**)

14 PENALTY SYSTEM

- 14.1 Unless the relevant NoR says otherwise, RRS 44.1 is changed so that the Two-Turns Penalty is replaced by the One-Turn Penalty
- 14.2 Redwings and BODs that may have broken one or more rules of Part 2 of the RRS or rule 31 inside the harbour and wish to take a penalty at the time of the incident shall not take that penalty inside the harbour, but shall take the penalty at the earliest opportunity outside the harbour entrance (an imaginary line between the groyne projecting from St Helens shore and the nearest point of land on Bembridge Point). This changes RRS 44.2.

15 TIME LIMITS

- 15.1 The race time limit (see RRS 35) is 3 hours. Boats failing to finish within 30 minutes of the first boat in their class or after the race time limit, whichever is later, will be scored "Did Not Finish". **This changes RRS 35, A4 and A5.**
- 15.2 Should no boat finish within the Race Time Limit, the result of the race for that class may be determined from a previously recorded time for all boats (taken at the finishing line or a rounding mark). **This changes RRS 35, A4 and A5.**
- 15.3 **If only one boat starts a race, or if all boats that started a race have retired except one, the**

Race Committee may abandon the race. This changes RRS 32.1.

16 HEARING REQUESTS

- 16.1 The protest time limit is 2 hours after the last boat in that class finishes the last race of the day or the race committee signals no more racing today, whichever is later.
- 16.2 Hearing request forms are available from the club office and website.
- 16.3 Notices will be posted no later than 30 minutes after the protest time limit to inform competitors of hearings in which they are parties or named as witnesses. Details of the location of the hearing will also be displayed.
- 16.5 RRS 66.2(2) is changed, replacing “30 minutes” by “one hour”.
- 16.6 The Post-Race Penalty, Advisory Meeting and RYA Arbitration procedures of the RYA Rules Disputes procedures shall apply. The outcome of an RYA Arbitration can be referred to a protest committee, but an arbitration cannot be reopened or appealed. See Appendix 4 for details.

17 SCORING

- 17.1 Details of the scoring for each series are specified in the club racing handbook.

18 SAFETY REGULATIONS

- 18.1 RRS 40.1 (Personal Flotation Devices, Basic Rule) applies at all times while afloat when:
- (i) the competitor is under 18 years of age, or
 - (ii) the competitor is sailing in a centre-board dinghy or small multi-hull, or
 - (iii) flag Y is displayed on the Committee Vessel.
- 18.2 A boat that retires from a race shall notify the race committee at the first reasonable opportunity – either by hailing the committee boat or patrol boat, by VHF channel 77 or M2(P4) or by telephone to BSC office 01983 872237.
- 18.3 When the race committee considers that a boat or competitor is in difficulty, it may instruct the boat or competitor to accept outside help, retire and sail ashore.

19 REPLACEMENT OF CREW OR EQUIPMENT

- 19.1 No authorisation is required for substitution of crew or equipment, except as required by class rules.

20 EQUIPMENT AND MEASUREMENT CHECKS

- 20.1 A boat or equipment may be inspected at any time for compliance with the class rules, notice of race and sailing instructions.

21 OFFICIAL VESSELS

- 21.1 Official vessels will be identified as follows:

Vessel Name/Call Sign	Description & Purpose
Sea Breeze	Main Committee Boat – Blue Hull and White Cabin
Zeta	Alternative Committee Boat – White Hull

- 21.2 All official vessels will fly the club burgee.

22 SUPPORT TEAMS

- 22.1 Support vessels shall stay outside the area where boats are racing.

22.2 Support personnel shall stay outside areas where boats are racing from the time of the preparatory signal for the first start until all boats have finished or retired or the race committee signals a postponement, general recall or abandonment.

22.3 Support person vessels shall be identified with club burgee.

23 TRASH DISPOSAL

23.1 Trash may be placed aboard official vessels. The penalty of breaking **RRS 47** may be less than disqualification.

24 PRIZES

24.1 Details of prizes for club events are given in the [BSC Club Racing Handbook](#).

25 RISK STATEMENT

25.1 **RRS 3** states: 'The responsibility for a boat's decision to participate in a race or to continue to race is hers alone.'

Sailing is by its nature an unpredictable sport and therefore inherently involves an element of risk. By taking part in the event, each competitor agrees and acknowledges that:

- a. They are aware of the inherent element of risk involved in the sport and accept responsibility for the exposure of themselves, their crew and their boat to such inherent risk whilst taking part in the event;
- b. They are responsible for the safety of themselves, their crew, their boat and their other property whether afloat or ashore;
- c. They accept responsibility for any injury, damage or loss to the extent caused by their own actions or omissions;
- d. Their boat is in good order, equipped to sail in the event and they are fit to participate;
- e. The provision of a race management team, patrol boats and other officials and volunteers by the event organizer does not relieve them of their own responsibilities;
- f. The provision of patrol boat cover is limited to such assistance, particularly in extreme weather conditions, as can be practically provided in the circumstances;
- g. It is their responsibility to familiarise themselves with any risks specific to this venue or this event drawn to their attention in any rules and information produced for the venue or event and to attend any safety briefing held for the event.

26 INSURANCE

26.1 Each participating boat shall be insured with valid third-party liability insurance with a minimum cover of £3million per incident or the equivalent.

Document completed on, Tuesday, 30th January 2024, reviewed by the RYA Race Management Advisory Team on 20th February 2024 and updated on 28th February 2024.

Special Course 1

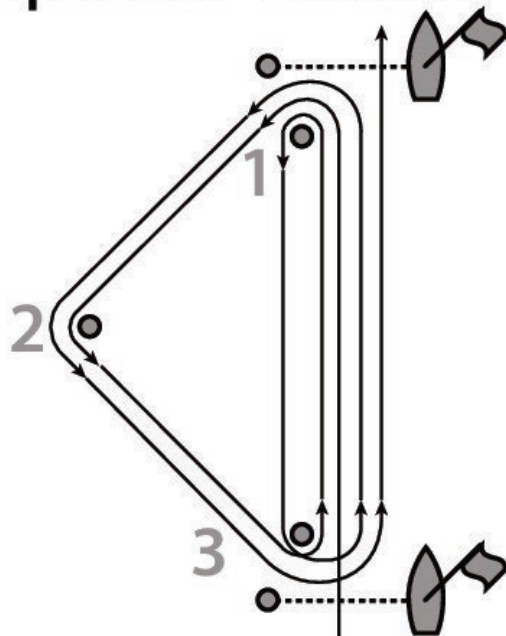

Start -1-2-3-1-3-1-2-3-Finish

*The Finish Committee Boat **may** be positioned between Marks 1 & 2.*

Special Course 2

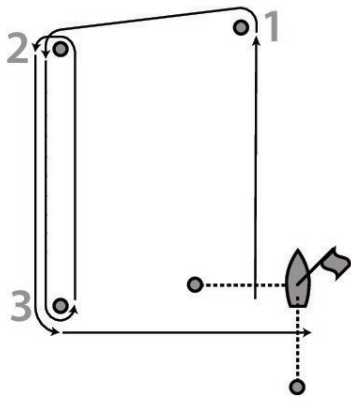

Start -1-2-3-2-3-Finish

Special Course 3

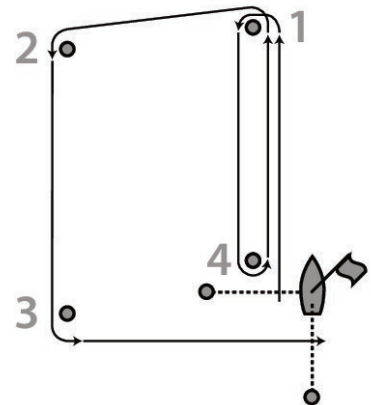

Start -1-4-1-2-3-Finish

Special Course 4

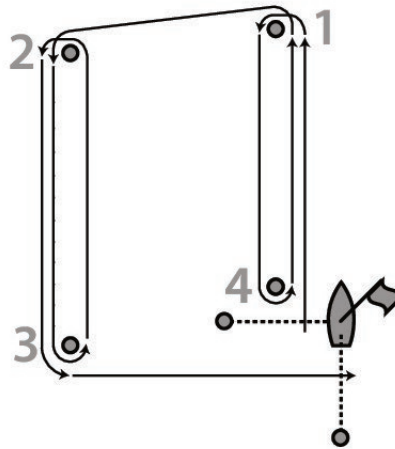

Start -1-4-1-2-3-2-3-Finish

Special Course 5

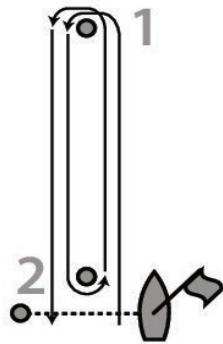

1 Round: Start -1-Finish

2 Rounds: Start -1-2-1- 2-Finish

Special Course 6

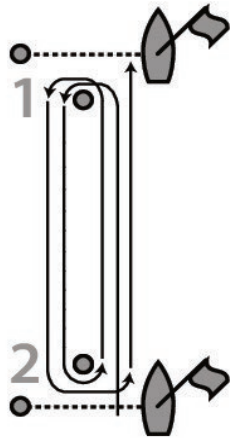

1 Round: Start -1-2-Finish

2 Rounds: Start -1-2-1- 2-Finish

The Start & Finish Committee boat may be positioned in the middle of the upwind leg.

In the event of there being a leeward gate, boats must pass through it on the way to the finish line.

Number of rounds indicated by the number of diamonds on a course board. The following course boards may also be used:

+W = Windward spreader

+L = Leeward spreader

+G = Leeward gate

The Start & Finish Committee boat may be positioned in the middle of the upwind leg.

In the event of there being a windward gate, boats must pass through it on the way to the finish line.

APPENDIX 2 – RACING MARKS AND BUOYS

EWCC RACING MARKS WITH ALLOTTED LETTERS, NUMBERS AND SYMBOLS		
A	ACLAND	Yellow Spherical/N Cone
B	BRITTEN	Yellow Spherical/Black Vertical Line
C	COCHRANE	Yellow Spherical
D	DRUMHEAD	Yellow Spherical
E	UNDER TYNE	Yellow Spherical
F	FITZWILLIAM	Yellow Spherical
G	GARLAND	Yellow Spherical with White Band
H	BRADING HAVEN TURNING MARK	Yellow Dan Buoy
I	NAB EAST	Red Channel Buoy
J	JONAH	Yellow Inflatable - Violet Top
JJ	JANSON (ex-PATCH)	Yellow Spherical with Black Band
jh	JENNY HUNTER	Yellow Spherical
K	DERRICK	Yellow Spherical with Orange Band
L	SEA VIEW LINE	Yellow Post
M	MORETON	Yellow Spherical with Orange Band
N	NAINBY LUXMOORE	Yellow Spherical
O	OLD CHURCH	Yellow Top Hat Buoy
Q	St HELENS	Red Channel Buoy
R	RUTHVEN	Yellow Spherical
S	LOLLIPOP	Yellow Inflatable - Yellow Top
T	TARA	Yellow Spherical
U	SOMERS	Yellow Spherical
V	BEMBRIDGE LEDGE	Yellow/Black East Cardinal
W	WRECK	Yellow Spherical
X	WARNER	Red Pillar Buoy
Y	FOOTPRINT	Yellow Top Hat Buoy
Z	NAB END	Red Pillar Buoy
!	NAB TOWER	Nab Tower
2	BRUCE	Yellow Inflatable - Orange Top
3	BERTIE	Yellow Spherical
4	PIERHEAD	Yellow Inflatable - Black Top
6	BROOKIE	Yellow Inflatable - Light Green Top
7	OUTER MARK	Yellow Spherical
8	LITTLE DEB	Yellow Inflatable - Mid-Blue Top
9	GORDON	Red Can
11	OLD 'O'	Yellow Top Hat Buoy
15	BOOM	Yellow Inflatable - Red Top
16	MAUDSLAY	Yellow Top Hat Buoy
@	BOB	Red Dan Buoy
	BUNNY	Yellow Inflatable - Pink Top
ILM(10)	SVYC INNER LINE (Orange Start)	Orange Dan Buoy
	SPENCE WILLARD	Yellow Top Hat Buoy
#	PEPE	Yellow Top Hat Buoy
†	BEMBRIDGE TIDE GAUGE	
▲	INFLATABLE MARK TO WINDWARD [OPTIONAL 2 □s FOR A DISTANT MARK]	
▼	INFLATABLE MARK TO LEEWARD [OPTIONAL 2 □s FOR A DISTANT MARK]	
◀▶	INFLATABLE WING MARK	
+	LAID OUTER LIMIT MARK (COMMITTEE BOAT START/FINISH)	
£	BOATS MUST GO THROUGH THE FINISH LINE ON EACH ROUND	
+W	WINDWARD SPREADER MARK (Special Courses 5 & 6)	
+L	LEEWARD SPREADER MARK (Special Courses 5 & 6)	
+G	GATE MARK (Special Courses 5 & 6)	

APPENDIX 3 – RACING BUOY CHART

CLASS FLAGS

	R flag Redwing		NNS flag Bembridge One Design		V flag Laser
	B flag Swallow		O flag Daring / Optimist		F flag RS Feva
	12 flag Illusion		Np 3 flag Handicap Class PY>1250		Np 4 flag Handicap Class PY<=1250
	Np 7 flag Scow		Np 9 flag Mermaid		NN9 flag Squib

COMMON SIGNALS

= Sound signal when displayed
 = Sound signal when removed

Orange flag
Committee Boat on station

Flag Y
Wear personal buoyancy

Flag P
Preparatory signal

Flag I
Round the ends penalty

Flag U
Rule 30.3 in effect

Flag Z
Rule 30.2 in effect 20% penalty

Black flag
Rule 30.4 in effect

Flag X
Individual recall

First substitute
General recall

Flag C
Change of course

Flag S
Shorten course

Blue flag
Committee Boat on station

Answering pennant
Races not started are postponed

Flag N
All races are abandoned Return to starting area

Flags N over A
All races are abandoned No more racing today

Flags N over H
All races are abandoned Further signals ashore

Flag E
IDM does not apply to this start

Flags H over D
Written parental consent required for cadet sailors

Starting Signals aide-memoire

5 minutes to GO
Display Class Flag
One Sound Signal

4 minutes to GO
Display Preparatory Flag
One Sound Signal

1 minute to GO
Remove Preparatory Flag
One Sound Signal

GO
Remove Class Flag
One Sound Signal

Individual recall
Display X Flag

General recall
One additional Sound Signal

6 minutes to GO
Display First Sub Flag
Two additional Sound Signals

Re-start sequence
Remove First Sub Flag
One Sound Signal

After one minute begin sequence again from the top

Bembridge Sailing Club
 Founded 1886
 Tel: 01983 872237
 training@bembridgesailingclub.org
 www.bembridgesailingclub.org
 radio: M2 (Bembridge Base)

APPENDIX 4 – RYA RULES DISPUTE PROCEDURES

X. Post-Race Penalty

- X.1 A boat that may have broken a rule of Part 2 of the Racing Rules of Sailing or rule 31 may, after finishing the race concerned and before the protest time limit or, if a hearing has been scheduled, before the start of that hearing, notify the race committee that it accepts a Post-Race Penalty – a 30% scoring penalty (SCP), based on the number of boats that came to the starting area in that race, except that the minimum penalty is three places and the boat shall not be scored worse than the number of boats that came to the starting area. However, if the boat caused injury or serious damage or, despite taking a penalty, gained a significant advantage in the race or series by its breach, its penalty shall be to retire.
- X.2 When a Post-Race Penalty is accepted: (a) neither the boat nor a protest committee may then revoke or remove the penalty. (b) the boat shall not be penalised further in a protest hearing when the protest committee decides that it was appropriate to the facts found and the applicable rules.

Y. Advisory Meeting

When there is an incident that will not result in the lodging of a protest or a request for redress, a boat may request an advisory meeting and notify any boat involved in the incident. An adviser will then call a meeting to learn what may have happened and will state whether any rule appears to have been broken, and by which boat. A boat may as a result notify the race office that it accepts a Post-Race Penalty when it applies to the incident, or choose to retire, but is not required to do so.

Z. RYA Arbitration

- Z.1 After a protest is lodged, a boat may request RYA Arbitration, or the protest committee or race committee may offer it.
- Z.2 If the parties and the protest committee agree that RYA Arbitration is suitable, an arbitrator (who may be a member of the protest committee) will call an arbitration. When it is the arbitrator's opinion that a boat that is a party to the arbitration has broken a rule for which the Post-Race Penalty is available, the party will be invited to accept that penalty and, if all such penalties are accepted, the protesting boat will be allowed to withdraw the protest, changing rule 63.1.
- Z.3 When any of the following conditions apply, 1. a party to the protest does not agree to RYA Arbitration, 2. the arbitrator's opinion is that the Post-Race Penalty is not applicable to the incident 3. a boat may be entitled to redress 4. a boat does not accept an offered Post-Race penalty, 5. the protest is not withdrawn, there will be a protest committee hearing. The arbitrator may be a member of the protest committee. Any boat is entitled to accept a Post-Race Penalty at any time before the later of the protest time limit or the start of the protest committee hearing and receive protection from further penalisation. The boat may also retire.
- Z.4 Rules 66 and 70 (reopening and appeal, respectively) do not apply to an RYA Arbitration since this is not a protest committee decision or procedure.